

DUCTILE IRON HINGED SURFACE BOX

**5 Years
Warranty**

SPECIFICATIONS

BRAND	
RANGE	- MANHOLE COVERS
PRODUCT CODE	- AX4545D
PRODUCT TYPE	- SOLID TOP
MATERIAL	- DUCTILE IRON

TECHNICAL INFORMATION

MANHOLE COVERS

CLEAR OPENING (NORMAL)-	150MM DIA
OVER BASE	- 250X250
DEPTH	- 100
LOADING	- D400

FEATURES

- BS EN 124 LOADING
- DUCTILE IRON GJS 500-7
- DOUBLE SEAL
- BADGING AS REQUIRED
- BLACK BITUMEN COATED
- EPOXY COATED

DRAWINGS

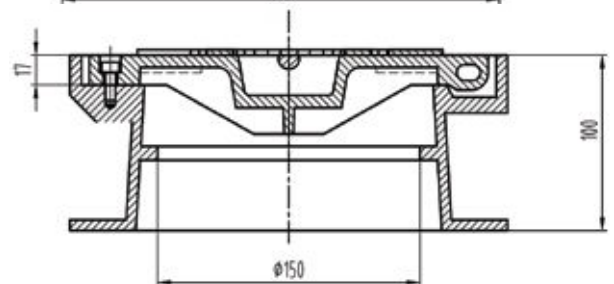
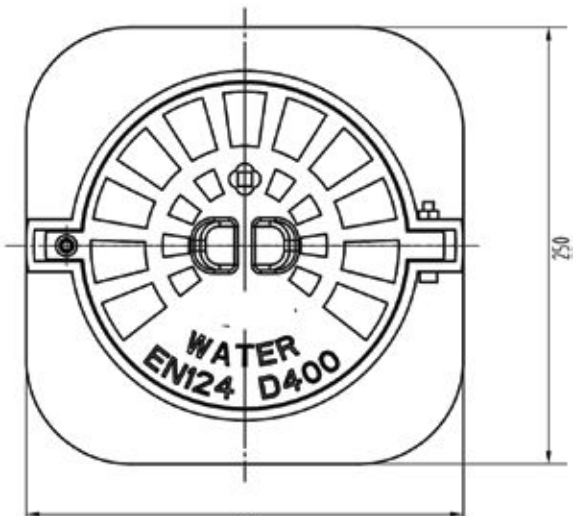
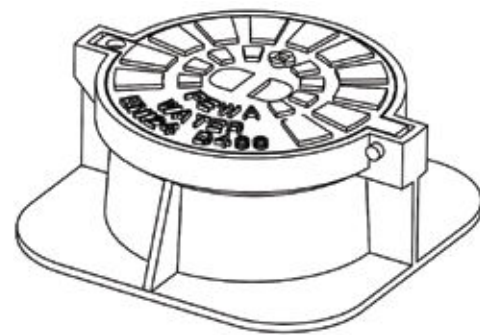

All dimensions in mm.
We reserve the rights to change the design/dimensions without any notice.

