

STAINLESS STEEL RECESSED TYPE FLOOR DRAIN

**20 Years
Warranty**

SPECIFICATIONS

BRAND	-	AQUANOX
RANGE	-	FLOOR DRAINS
PRODUCT CODE	-	570
PRODUCT TYPE	-	FLOOR DRAIN
MATERIAL	-	STAINLESS STEEL

TECHNICAL INFORMATION

FLOOR DRAIN WITH COVER		
SIZE	-	150X150MM
HEIGHT	-	126X126
SIDE OUTLET	-	100

MATERIAL	FINISH
SS304 GRADE <input type="checkbox"/>	MIRROR FINISH <input type="checkbox"/>
SS316 GRADE <input type="checkbox"/>	BRUSH FINISH <input type="checkbox"/>

OPTIONAL EXTRAS
STAINLESS STEEL 304 <input type="checkbox"/>
STAINLESS STEEL 316 <input type="checkbox"/>



DRAWINGS

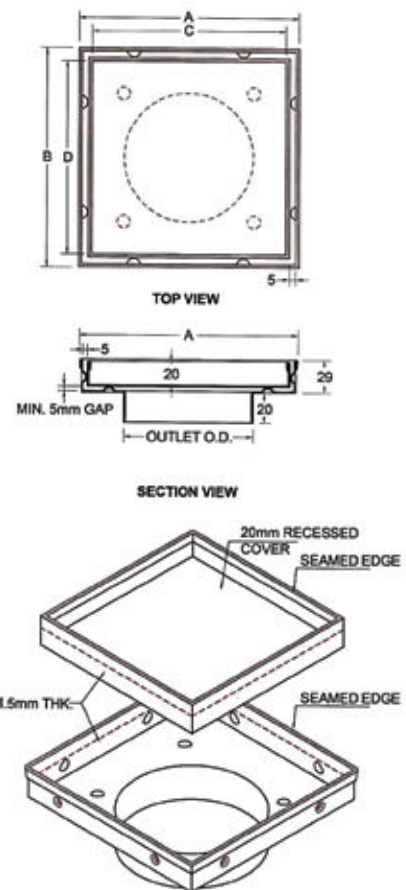

All dimensions in mm.
We reserve the rights to change the design/dimensions without any notice.