

# STAINLESS STEEL FLOOR DRAIN COVER

**20 Years**  
Warranty

## SPECIFICATIONS

BRAND	-	AQUANOX
RANGE	-	FLOOR DRAINS
PRODUCT CODE	-	115
PRODUCT TYPE	-	FLOOR DRAIN
MATERIAL	-	STAINLESS STEEL

## TECHNICAL INFORMATION

FLOOR DRAIN WITH COVER		
SIZE	-	100 X 100MM
HEIGHT	-	14
SIDE OUTLET	-	51

MATERIAL	FINISH
SS304 GRADE <input type="checkbox"/>	MIRROR FINISH <input type="checkbox"/>
SS316 GRADE <input type="checkbox"/>	BRUSH FINISH <input type="checkbox"/>

OPTIONAL EXTRAS
STAINLESS STEEL 304 <input type="checkbox"/>
STAINLESS STEEL 316 <input type="checkbox"/>



## DRAWINGS

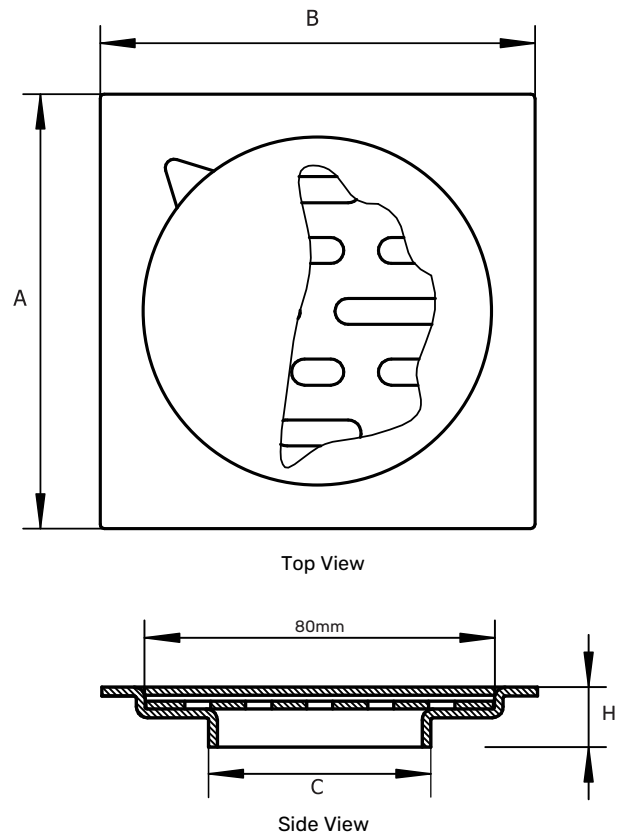

All dimensions in mm.  
We reserve the rights to change the design/dimensions without any notice.