

STAINLESS STEEL HINGED TYPE FLOOR DRAIN COVER

20 Years
Warranty

SPECIFICATIONS

BRAND	-	AQUANOX
RANGE	-	FLOOR DRAINS
PRODUCT CODE	-	545
PRODUCT TYPE	-	FLOOR DRAIN
MATERIAL	-	STAINLESS STEEL

TECHNICAL INFORMATION

FLOOR DRAIN WITH COVER		
SIZE	-	150X150MM
HEIGHT	-	28
SIDE OUTLET	-	101

MATERIAL	FINISH
SS304 GRADE <input type="checkbox"/>	MIRROR FINISH <input type="checkbox"/>
SS316 GRADE <input type="checkbox"/>	BRUSH FINISH <input type="checkbox"/>

OPTIONAL EXTRAS
STAINLESS STEEL 304 <input type="checkbox"/>
STAINLESS STEEL 316 <input type="checkbox"/>



DRAWINGS

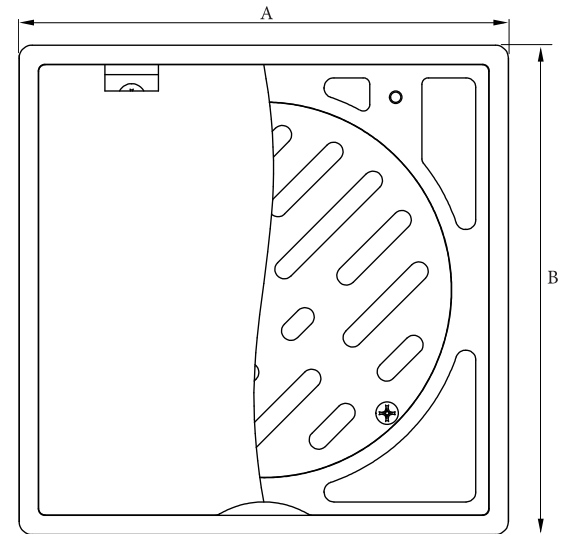

Top View

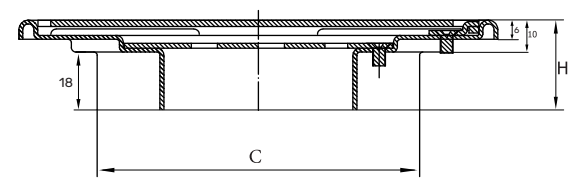

Side View

All dimensions in mm.
We reserve the rights to change the design/dimensions without any notice.

