

STAINLESS STEEL FLOOR DRAIN COVER

20 Years
Warranty

SPECIFICATIONS

BRAND	-	AQUANOX
RANGE	-	FLOOR DRAINS
PRODUCT CODE	-	551
PRODUCT TYPE	-	FLOOR DRAIN
MATERIAL	-	STAINLESS STEEL

TECHNICAL INFORMATION

FLOOR DRAIN WITH COVER		
SIZE	-	150X150MM
HEIGHT	-	19
SIDE OUTLET	-	102

MATERIAL	FINISH
SS304 GRADE <input type="checkbox"/>	MIRROR FINISH <input type="checkbox"/>
SS316 GRADE <input type="checkbox"/>	BRUSH FINISH <input type="checkbox"/>

OPTIONAL EXTRAS
STAINLESS STEEL 304 <input type="checkbox"/>
STAINLESS STEEL 316 <input type="checkbox"/>



DRAWINGS

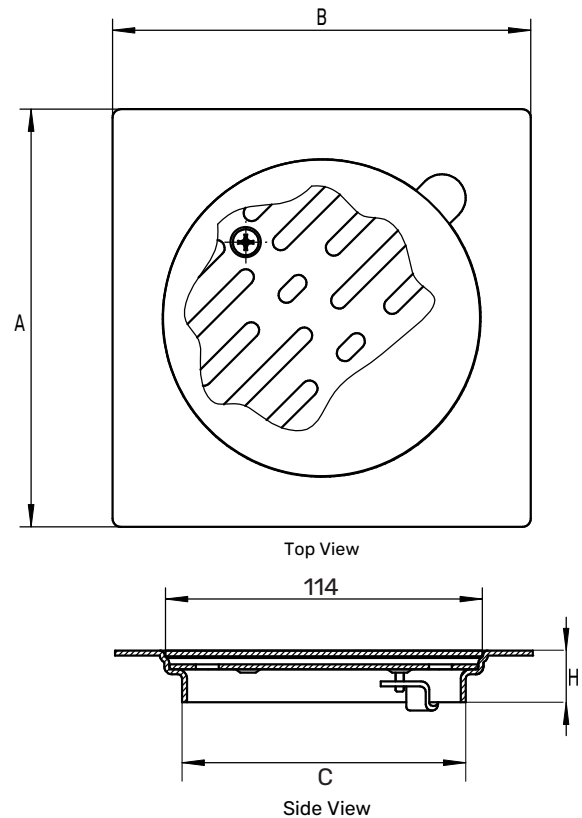

All dimensions in mm.
We reserve the rights to change the design/dimensions without any notice.